



A General-Purpose Pulse Generator Producing High-Power, Fast-Rise Pulses

FAST risetime pulses with appreciable power at high repetition rates are used to advantage in a growing number of applications. The testing of magnetic cores, ferrite modulators, high speed relays, and high power semiconductor devices represent some of the uses for pulses of considerable

current. Pulses with ample voltage are useful for testing power amplifiers, wideband modulators, and the ionization times of neon bulbs, thyratrons, and other gaseous devices.

To meet this demand for high power pulses

with fast risetimes, a new general purpose pulse generator has been designed to supply up to 200 watts in its output pulse at repetition rates up to 1 Mc. Maximum pulse amplitude into a 50 ohm load is 100 volts, four times the power previously available in a general purpose pulse generator. Maximum pulse current into a short circuit is 2 amperes. Pulse rise and fall times at 100 volts are typically less than 15 nsec and are reduced to less than 13 nanoseconds for pulse amplitudes of 50 volts (into 50 ohms) or less.

The new generator, -hp- Model 214A, complements the performance range of other recently-announced -hp- generators. The Model 215A

SEE ALSO:
A new clip-on current probe, page 5
Increased power for VLF standard broadcasts, page 8

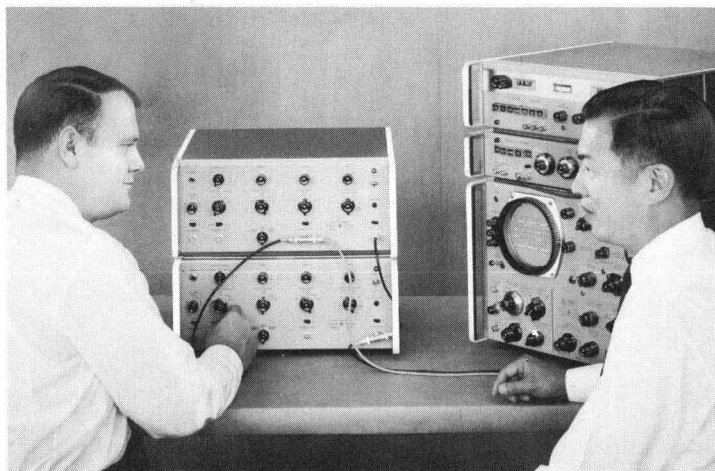

Fig. 1. Model 214A Pulse Generators can be connected in parallel to derive complex pulse trains, as shown here in RF modulation experiment. Flexible synchronizing and triggering capabilities increase possible variety of pulse trains.

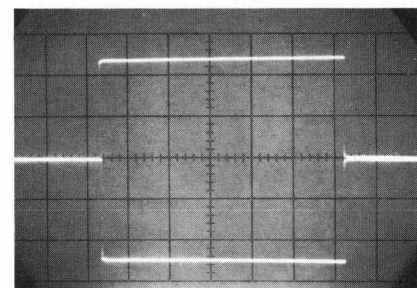

Fig. 2. Either positive or negative rectangular pulses, both with baseline fixed at ground, are available from -hp- Model 214A Pulse Generator. Double exposure oscillogram shows both pulse polarities; only output polarity switch was changed between exposures. (Sweep speed: 5 μ sec/cm; vertical sensitivity: 5 v/cm).

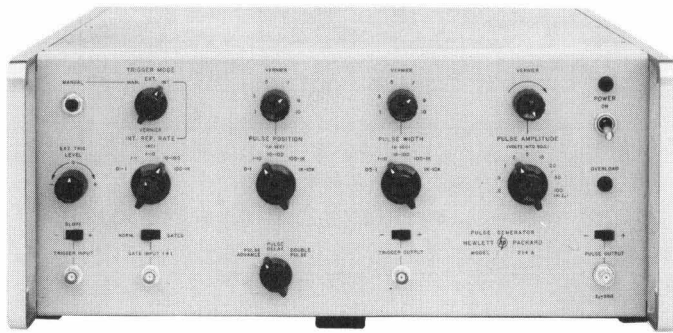

Fig. 3. Hewlett-Packard Model 214A Pulse Generator.

nanosecond Pulse Generator, for instance, has a maximum pulse amplitude of 10 volts and pulse widths ranging between 2 and 100 nsec but extremely fast pulse rise and fall times of only 1 nsec¹. The Model 213B on the other hand has a risetime of less than 0.1 nsec, the fastest available, with a pulse amplitude of 175 mv².

In addition to high power, the new 214A has the wide flexibility required of a general purpose instrument. Pulse width can be varied from 50 nsec to 10 msec in 5 ranges. Pulse amplitude can be reduced from 100 volts to less than 80 mv through a nine position range switch and a 2.5:1 vernier control. The pulse baseline is fixed at ground for either positive or negative output pulses (Fig. 2) and does not shift regardless of pulse width,

¹C. O. Forge, "A New Pulse Generator with Very Fast Risetime," Hewlett-Packard Journal, Vol. 14, No. 2, October, 1962.

²R. Carlson, "A Tunnel-Diode Pulse Generator with 0.1 Nanosecond Risetime," Hewlett-Packard Journal, Vol. 14, No. 12, August, 1963.

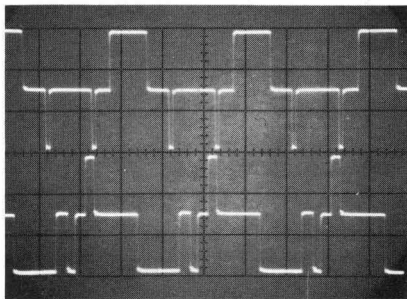

Fig. 4. Waveforms shown here were made by two Model 214A Pulse Generators connected in parallel. One generator (narrow pulses) operated in double pulse mode.

pulse polarity, or pulse repetition rate. This is important when the generator drives circuits which cannot tolerate dc bias changes.

Other features of the instrument include a high order of triggering flexibility, a 50 ohm driving source impedance, and the capability of providing double pulses. In addition, two or more 214A pulse generators may be connected in parallel to provide a variety of pulse trains.

PULSE CHARACTERISTICS

The characteristics of the 214A output pulse are fully specified so that measurements concerned with the shape of a test pulse can be made with confidence. Overshoot is less than 5% on both leading and trailing edges, preshoot is less than 2%, pulse top perturbations are less than 4%, and sag on the longest pulse is less than 5%. Of particular importance is the fact that pulse characteristics do not vary with changes in repetition rate or pulse width settings.

The broad range of pulse widths enables the 214A to serve as a square wave generator when operating on the 10 volt or lower amplitude ranges (duty cycle is limited to an average power of 20 watts).

In all but the highest voltage range of the instrument, a 50 ohm internal resistance is connected across the output to serve as an internal termination for absorption of pulse reflections from external circuits. This enables the 214A to work into mismatched loads with a mini-

mum of pulse distortion which otherwise results from secondary reflections*. It is thus possible to use the short-circuit current capabilities of the output stage without seriously degrading the pulse shape (Fig. 5).

On the highest voltage range, the internal 50 ohm termination is disconnected and the output stage then supplies a 100 volt pulse into a 50 ohm load, or 180 volts to an open circuit. Short circuit output current with or without the internal 50 ohm termination is 2 amperes.

TRIGGER FLEXIBILITY

The 214A can be triggered by a wide variety of triggering pulses, oscilloscope type triggering controls enabling the instrument to be triggered from any waveform having more than a 1/2 volt peak amplitude. The generator triggers at any repetition rate from 0 to 1 Mc, or free-runs throughout a range of 10 cps to 1 Mc in 5 ranges. Single pulses can be generated in response to a front panel push-button, a useful feature for determining the minimum single impulse energy needed to trigger a circuit. Pulse bursts are also available, an internal gate lock-

*Tube capacitance causes small reflections on very fast transients; these are reduced on the lower voltage ranges by the attenuator pads in series with the output.

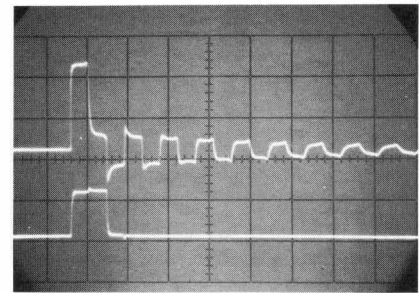

Fig. 5. Effect of internal termination is shown in lower waveform. This represents current at shorted end of 3-ft coaxial cable while generator internal 50 Ω termination is connected (50 v range). Upper waveform shows current at end of same shorted cable with internal 50 Ω termination switched out (100 v range). Mismatched ends of cable cause multiple reflections. (Sweep speed: 1 μ sec/cm; vertical sensitivity: 2 amps/cm.)

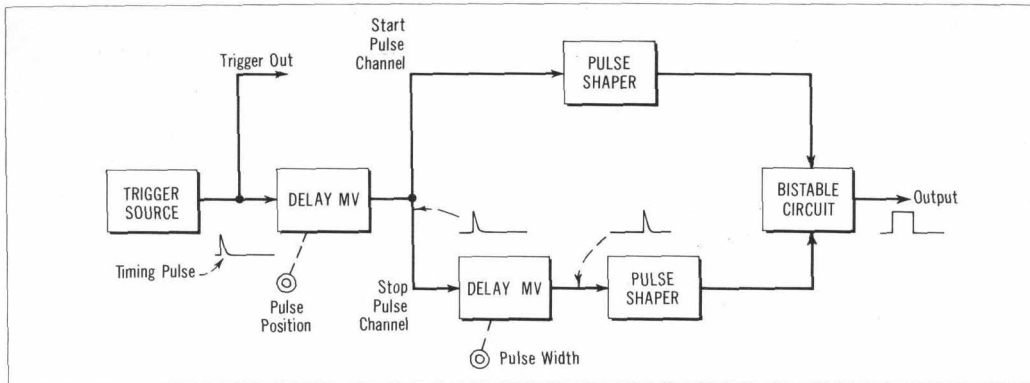

Fig. 6. Skeleton block diagram shows basic configuration of -hp-Model 214A Pulse Generator in Pulse Delay mode.

ing out trigger pulses except when an external gate signal is applied.

OUTPUT TRIGGER

In addition to the main pulse, the 214A supplies a trigger pulse for operation of external equipment. The trigger pulse may be set to occur in advance of or delayed from the main pulse throughout a range of +10 milliseconds to -10 milliseconds. The wide range of trigger delays facilitates oscilloscope examination of different parts of the pulse and also enables a variety of complex pulse trains to be generated when several 214A pulse generators are used in combination.

DOUBLE PULSES

Double pulses are obtained when the output trigger delay generator is switched to serve as an internal trigger source for generating a second pulse following the primary pulse. Obviously, the pulse width

and amplitude controls affect both pulses equally. Time delay between the leading edges of the pulses is controllable up to 10 milliseconds by the trigger delay control. Minimum pulse spacing depends on the pulse width setting, of course.

Double pulses are useful for testing the resolution of digital circuits and also find use where 214A's are used in combination to provide special pulse trains (Fig. 4), as in testing magnetic cores.

DETAILS OF OPERATION

The output pulse is generated by a bistable circuit that includes the power output tubes. Despite recent advances in semiconductor devices, tubes are still the most economical choice for generation of high power, fast rise pulses. High-perveance pentodes, rather than thyatrons, are used here to permit a 1 Mc pulse repetition rate. As outlined by the

block diagram of Fig. 6, the output circuit is turned on by a start trigger pulse and turned off by a stop trigger pulse. Pulse width therefore is determined solely by the time difference between the two pulses.

When the instrument is in the Pulse Delay mode, as shown in Fig. 6, the timing pulses pass directly to the sync trigger blocking oscillator. The output of this circuit may be used to trigger external equipment in advance of the main pulse.

To place the main pulse ahead of the sync trigger pulse, the circuits are re-arranged in the Pulse Advance mode, as shown in Fig. 7. The timing pulse now triggers the start and stop circuits directly, while the pulse position multivibrator triggers the sync trigger blocking oscillator at a later instant (a fixed delay in the trigger out circuits creates a small overlap between pulse advance and delay modes).

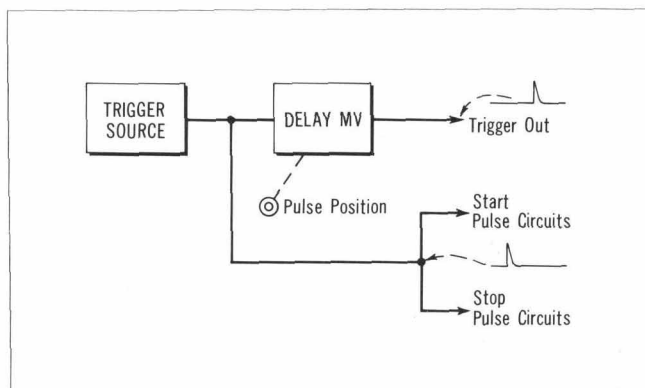

Fig. 7. Pulse advance configuration places main pulse ahead of trigger pulse.

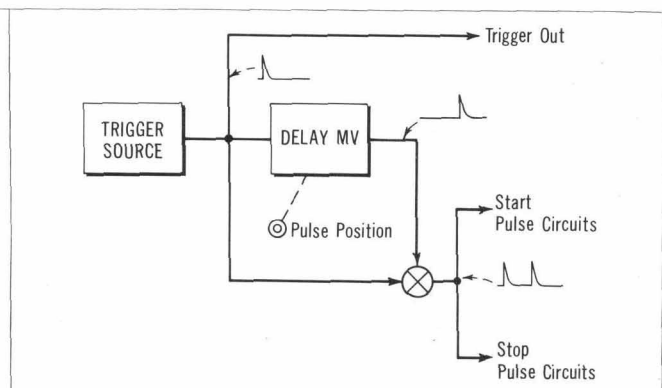

Fig. 8. Double pulse configuration uses Pulse position delay multivibrator to trigger main pulse circuits for second time.

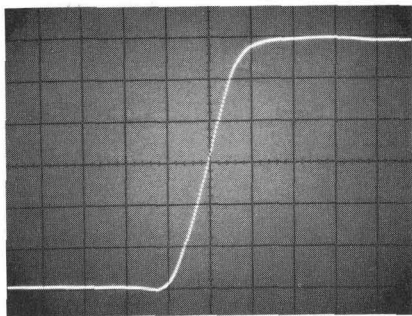
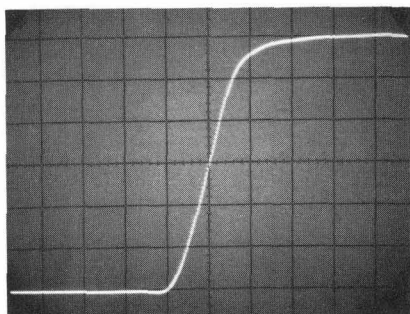

Fig. 9. Leading edge of 50 v pulse is shown above; 100 v pulse is below. (Sweep speed in both photos: 10 nsec/cm.)



Double output pulses are obtained in the *Double Pulse* mode, shown in Fig. 8. In this case, the timing pulse triggers both the sync trigger and main pulse controls circuits directly. The main pulse circuits are triggered a second time, however, by the pulse position multivibrator. Two main pulses thus are generated, with the time between leading edges controlled by the *Pulse Position* control. The output trigger now remains fixed in

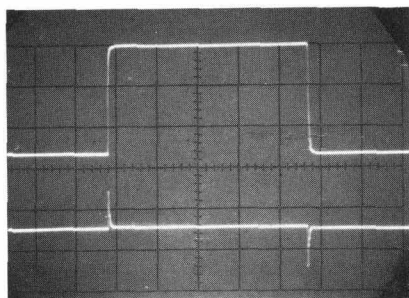
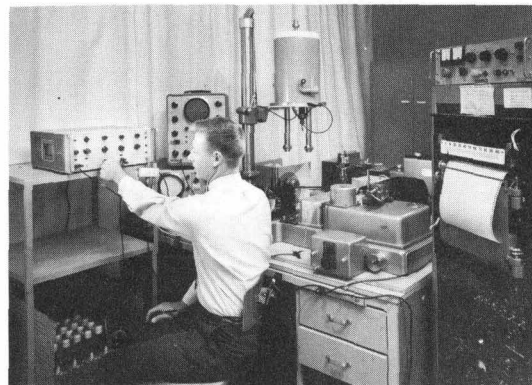

Fig. 10. Current drive capability of Model 214A is shown by current waveform (200 ma/cm) in 2.2 μ h inductor connected across generator output (upper trace). Lower trace shows voltage waveform (20 v/cm). (Sweep speed: 2 μ sec/cm.)

Fig. 11. Model 214A Pulse Generator supplies up to 2 amperes of pulsed forward current for study of light spectra radiated by electroluminescent diodes. In laboratory setup shown here, Display Scanner in -hp- 175A Oscilloscope synchronized with pulse generator "reads" photocell output only during brief sampling interval, thereby improving signal-to-noise ratio.



time with respect to the leading edge of the first main pulse.

Either positive or negative output pulses are obtained by a reversing switch on the output leads. Transmission-line transformer baluns invert the output without pulse degradation in either polarity.

Output amplitude is controlled through a 2.5:1 vernier range by adjustment of the output tube screen voltage. Amplitude range switching adjusts bias levels throughout the

output circuit to reduce output power, as well as switching in an output attenuator.

ACKNOWLEDGMENT

Hewlett-Packard engineers who contributed to the design of the Model 214A Pulse Generator include Eugene Acton, Yi Him Co, and Robert Schweizer in addition to the undersigned.

— George Kan and
Johan Blokker

SPECIFICATIONS

-hp- MODEL 214A PULSE GENERATOR

OUTPUT PULSE

SOURCE IMPEDANCE: 50 ohms on 50-volt and lower ranges; approximately 1500 ohms on 100-volt range.

PULSE SHAPE:

RISE AND FALL TIMES: <13 nsec on 20-volt and lower ranges and on 50 v negative pulse, typically <10 nsec with vernier set for maximum attenuation; <15 nsec on 50 v positive pulse. Typically 15 nsec on 100 v range.

PULSE AMPLITUDE: 100 volts into 50 ohms. Attenuator provides 0.2 to 100 volts in 1, 2, 5, 10 sequence (9 ranges). Vernier provides continuous adjustment between ranges and reduces output of lowest range to 80 mv.

POLARITY: Positive or negative selectable by front panel switch.

OVERSHOOT: <5% on both leading and trailing edges.*

PULSE TOP VARIATIONS: <4%.

DROOP: <5%.

PRESHOOT: <2%.

PULSE WIDTH: 50 nsec to 10 ms in 5 decade ranges. Continuously adjustable vernier.

WIDTH JITTER: <0.05% of pulse width + 1 nsec.

PULSE POSITION: 0 to 10 ms advance or delay with respect to trigger output (5 decade ranges). Continuously adjustable vernier.

JITTER: <0.05% of advance or delay setting + 1 ns (between trigger pulse and output pulse).

REPETITION RATE AND TRIGGER

INTERNAL:

REPETITION RATE: 10 cps to 1 Mc (5 ranges), continuously adjustable vernier.

RATE JITTER: <0.5% of period.

MANUAL: Push-button single pulse, 2 cps maximum rate.

EXTERNAL:

REPETITION RATE: dc to 1 Mc.

SENSITIVITY: <0.5 vpk.

SLOPE: Positive or negative.

LEVEL: Adjustable from -40 v to +40 v.

EXTERNAL GATING: +8-volt signal gates pulse generator on. Maximum input, 40 vpk.

DOUBLE PULSE:

MINIMUM SPACING: 1 μ sec on 0.05 to 1 μ s pulse width range and 25% of upper limit of width range for all other ranges.

TRIGGER OUTPUT:

AMPLITUDE: 10 v into 1000 ohms.

WIDTH: 0.05 μ sec, nominal.

POLARITY: Positive or negative.

GENERAL

MAXIMUM DUTY CYCLE: 10% on 100- and 50-volt ranges; 25% on 20-volt range; 50% on 10-volt and lower ranges.

POWER: 115 or 230 v \pm 10%, 50 to 60 cps, 325 watts.

DIMENSIONS: 7" high, 16 $\frac{3}{4}$ " wide, 18 $\frac{3}{8}$ " deep.

WEIGHT: Net, 35 lbs. Shipping, 48 lbs.

PRICE: -hp- Model 214A, \$875.00.

*Measured on 50-Mc oscilloscope

Prices f.o.b. factory
Data subject to change without notice

A CLIP-ON CURRENT PROBE FOR WIDE-BAND OSCILLOSCOPE MEASUREMENTS

SOME five years ago the *-hp-* laboratories developed a precision milliammeter that measured current merely by clipping a special probe around the conductor in question^{1,2}. The probe thus avoided the need for breaking the circuit to make a measurement, a convenience appreciated by all. At the same time the probe had the additional advantage that it introduced virtually no loading into the circuit being measured. The immediate acceptance of this clip-on probe, which was designed for dc measurements, subsequently led to the development of two ac current probes which have been widely used^{3,4}.

A new clip-on probe for ac current has now been developed especially for oscilloscope use. By itself, the probe has a medium sensitivity

and a frequency range that extends to above 40 megacycles with a corresponding pulse risetime of less than 9 nanoseconds. However, most of its capabilities other than high-frequency response are extended if the probe is used with a companion amplifier. In that case the bandwidth of the combination becomes 20 megacycles (18 nsec risetime), while the sensitivity is increased to 1 milliamperes per oscilloscope division for oscilloscopes having a 50-millivolt/cm sensitivity, the usual basic value for wide-band oscilloscopes. Further, the combination has an adjustable sensitivity and can be used to measure up to 50 amperes peak-to-peak. The probe by

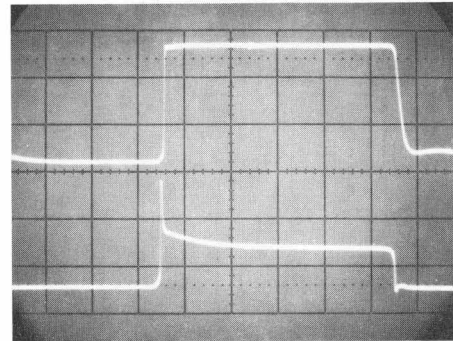

itself or the combined probe/amplifier can be used with any of the *-hp-* oscilloscopes. The probe by itself is particularly useful with the *-hp-* sampling oscilloscopes (Models 185A/B), since the widest probe frequency response is obtained with these scopes.

PROBE

When used without the amplifier, the probe has a very wide frequency response and a sensitivity suitable for medium-level measurements. The basic sensitivity is an output of 1 millivolt per milliamperes flowing in the measured conductor. Operated by itself, the probe has a pulse response typified by the oscillogram in Fig. 6 and a frequency response

¹Arndt Bergh, Charles O. Forge, and George S. Kan, "A Clip-On DC Milliammeter For Measuring Tube and Transistor Circuit Currents," *Hewlett-Packard Journal*, Vol. 9, No. 10-11, June-July, 1958.

²Donald E. Barkley and Arndt Bergh, "Broader Information Capabilities in the Clip-On DC Milliammeter," *Hewlett-Packard Journal*, Vol. 13, No. 3-4, Nov.-Dec., 1961.

³Robert R. Wilke, "A Clip-On Oscilloscope Probe For Measuring and Viewing Current Waveforms," *Hewlett-Packard Journal*, Vol. 10, No. 9-10, May-June, 1959.

⁴Charles O. Forge, "A New Clip-On Oscilloscope/Voltmeter Probe For 25 cps—20 Mc Current Measurements," *Hewlett-Packard Journal*, Vol. 11, No. 11-12, July-Aug., 1960.

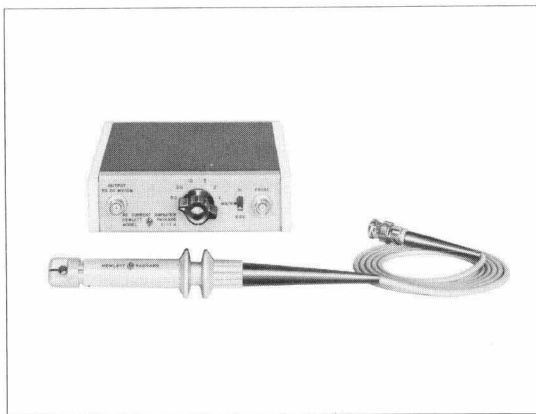

Fig. 2. *-hp-* Model 1110A AC Current Probe and Model 1111A Amplifier. Probe clips around conductor being measured.

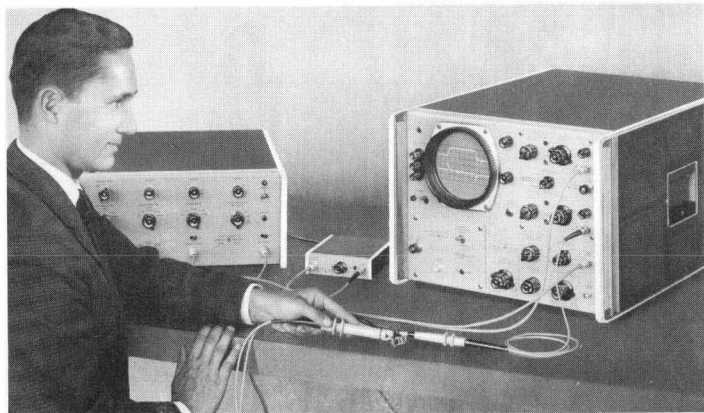

Fig. 3. Typical test setup using new clip-on current probe together with voltage probe to simultaneously observe and measure current and voltage in test circuit.

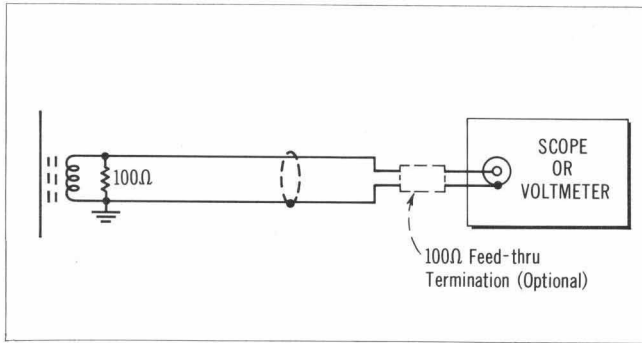

Fig. 4. Circuit representation of *-hp-1110A* probe as used with scope or voltmeter.

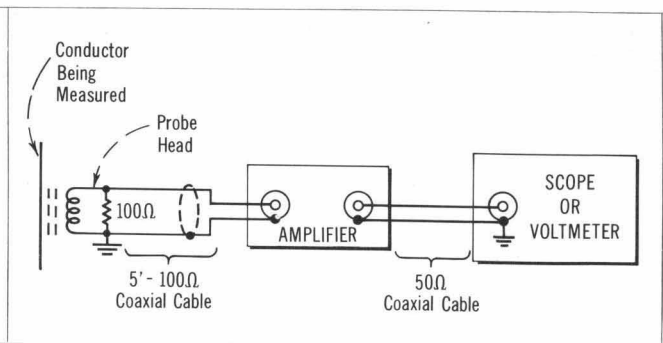

Fig. 5. Circuit representation of *-hp-1110A/1111A* probe and amplifier in typical setup.

typified by the curves in Figs. 8(a) and 8(c).

The relatively small perturbations in the pulse response of Fig. 6 can be reduced further and the probe's low-frequency response extended if the probe is operated with a resistive termination at the end of its output cable. The probe head is designed as a current transformer using the conductor being measured as a one-turn primary. The secondary is shunted with 100 ohms to provide a 100-ohm source impedance and drives a 100-ohm coaxial cable. The arrangement is such that reflections from the open end of the cable are absorbed almost completely, as indicated by the quality of the response in Fig. 6. However, terminating the open end of the cable in 100 ohms further reduces reflections and standing-wave patterns, although at the expense of a 50% reduction in sensitivity. The oscillogram of Fig.

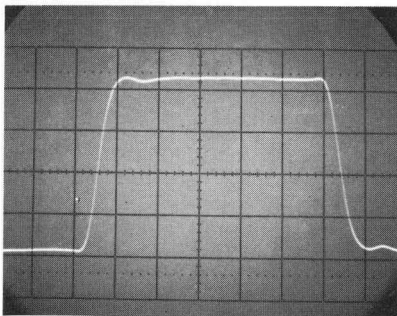

Fig. 6. Oscilloscope of typical pulse response of *-hp-1110A* probe operating directly into high-impedance oscilloscope (*-hp-175A/1751A*).

7 shows the typical pulse response when the probe cable is terminated, and Fig. 8(c) the typical low-frequency response which now extends from below 1 kilocycle (to above 40 megacycles as in Fig. 8(a)). The effect of an oscilloscope input capacitance of 30 pf is shown in the response curve of Fig. 8(a). When the probe cable is terminated, the sensitivity becomes 0.5 mv/ma, as indicated by the reduced pulse height in Fig. 7. The *-hp-#10100B* 100-ohm termination is designed for terminating the probe cable and was used for the data shown.

The probe is especially valuable for fast current measurements in low-impedance circuits because it reflects only a slight impedance into the circuit being measured. This impedance is approximately .01 ohm shunted by 1 μ h. The capacitance to ground when the probe is clamped on a #22 gage wire is less

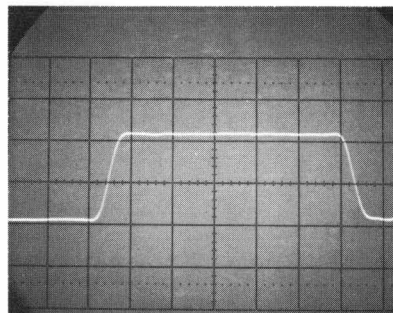

Fig. 7. Same as Fig. 6 except probe cable terminated with *-hp-10100B* 100-ohm termination, as in Fig. 4.

than 3 pf. An electrostatic shield is located between the probe head and a measured wire, and a magnetic shield surrounds the probe head to reduce the effects of external magnetic fields.

The probe has the ability to measure very high currents before the ferrite core is driven into its non-linear region (Fig. 8(e)). With a 100-ohm termination the current probe itself can measure up to 30 amperes p-p above 4 kc and greater values when used with the amplifier, as shown in Fig. 8(f). The maximal allowable measured current is lower at low frequencies because of core distortion and is lower at high frequencies due to heating in the core. Somewhat more than 0.5 ampere dc can be flowing in the conductor being measured before distortion of the ac measurement is noticeable.

PROBE WITH AMPLIFIER

Using the probe with the amplifier provides additional sensitivity and low-frequency response (Fig. 8(d)), and also provides a very useful 50-ohm output impedance so that the response is not critical with different load capacities or lengths of output cable (Fig. 8(b)). The frequency response of the combined probe/amplifier is from 50 cps to 20 Mc at the -3 db points with a pulse risetime of approximately 18 nanoseconds and a low frequency pulse sag of 3% in 0.2 millisecond.

When used with the amplifier,

the probe has a basic current-to-voltage conversion of 50 mv/ma. This is calibrated on the amplifier panel as 1 ma/cm which requires that the oscilloscope be set for 50 mv/cm. Current will then be direct-reading in milliamperes on the oscilloscope screen. An attenuator and range switch on the amplifier reduce the basic sensitivity in a 1-2-5 sequence from 1 ma/cm to 5000 ma/cm in 12 ranges. Fig. 3 shows a typical test setup using the probe/amplifier combination.

GENERAL

Current measurements using the -hp- clip-on current probes are in many cases more convenient and more accurate than voltage measurements and can yield information that would not otherwise be obtained. Such measurements as transistor base and emitter currents, tube screen currents, load resistor currents measured on the power supply side of the resistor where capacity has no effect, current summing and equalizing by measuring two current-carrying conductors simultaneously, power supply ripple, current-voltage comparisons, and charging currents and turn-on surges are especially valuable. The probe is marked to indicate its directional sense in terms of conventional current flow.

The high-frequency capability of the probe and amplifier means that an awareness of high-frequency ground current effects is important. The standard precautions regarding grounding and low inductance are in order. A resistive ground lead is provided with the probe for damping of ground-loop resonances.

ACKNOWLEDGMENT

The design group for the probe and amplifier included Arthur M. Johnston, James M. Umphrey and the undersigned. Valuable suggestions were provided by Arndt Bergh and Norman B. Schrock.

— John G. Tatum

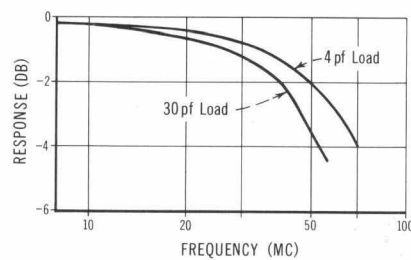

TYPICAL HIGH-FREQUENCY RESPONSE OF -hp- MODEL 1110A PROBE WITH 100-OHM TERMINATION (-hp- 10100B) (a)

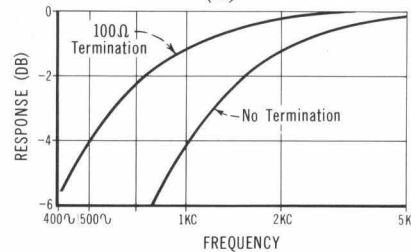

TYPICAL LOW-FREQUENCY RESPONSE OF -hp- MODEL 1110A PROBE (c)

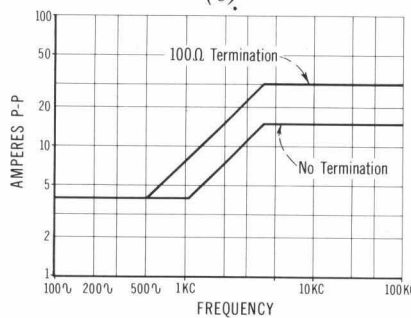

MAXIMUM CURRENT RATING OF -hp- MODEL 1110A PROBE (e)

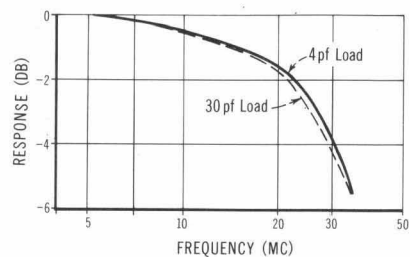

TYPICAL HIGH-FREQUENCY RESPONSE OF -hp- MODEL 1110A PROBE WITH 1111A AMPLIFIER USING 3' OF 50-OHM CABLE (b)

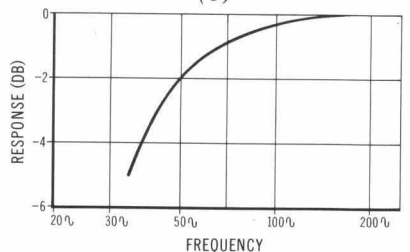

TYPICAL LOW-FREQUENCY RESPONSE OF -hp- MODEL 1110A PROBE WITH 1111A AMPLIFIER (d)

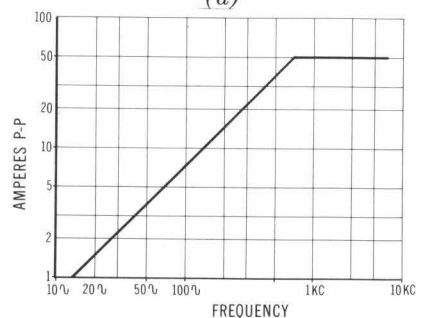

MAXIMUM CURRENT RATING OF -hp- MODEL 1110A PROBE WITH 1111A AMPLIFIER (f)

Fig. 8. Typical performance data for -hp- 1110A AC Current Probe and 1111A Amplifier.

-hp- MODEL 1110A AC CURRENT PROBE (without amplifier)	SPECIFICATIONS	-hp- MODEL 1110A AC CURRENT PROBE AND MODEL 1111A AMPLIFIER
SENSITIVITY: 1 mv/ma.		SENSITIVITY: 1 ma/cm to 50 ma/cm in X1, and 100 ma/cm to 5 amps/cm in X100 — 1,2,5 sequence.
ACCURACY: ±3%.		ACCURACY: ±3% on 50 ma/cm sensitivity and below; ±4% on 100 ma/cm sensitivity and above.
BANDWIDTH: 4 PF LOAD: (e.g. 185B/187B), 1700 cps to greater than 50 mc, 7 nsec rise-time. 30 PF LOAD: (e.g. 175A/1750A), proportional decrease (capacity vs frequency) to 40 mc, 9 nsec rise-time.		BANDWIDTH: 50 cps to 20 mc (18 nsec rise-time).
MAXIMUM DC CURRENT: 0.5 ampere.		NOISE: Less than 100 μa p-p, referred to input.
MAXIMUM AC CURRENT: 15 amperes p-p above 4 kc; decreasing below 4 kc at the rate of 3.8 amps/kc (30 amps p-p max. with -hp- No. 10100B 100-Ohm termination).		MAXIMUM AC CURRENT: 50 amps p-p above 700 cps, decreasing below 700 cps at the rate of 1.4 amps/20 cps.
INSERTION IMPEDANCE: Approximately 0.01 ohm, shunted by 1 μh; capacity to ground is less than 3 pf.		OUTPUT IMPEDANCE: 50 ohms.
ACCESSORY AVAILABLE: -hp- 10100B 100-ohm feed-through termination; decreases sensitivity to 0.5 mv/ma, lower cutoff to 850; increases maximum ac current to 30 amps p-p above 4 kc. Price, \$17.50.		DIMENSIONS: Amplifier: 1½ in. high, 5½ in. wide, 6 in. deep. Probe: Aperture, ½ in. diameter, 5 ft. cable.
		WEIGHT: Approximately 2 lbs.
		POWER: 115 or 230 volts ±10%, 50 to 60 cps, approximately 1.5 watts.
		PRICE: Model 1110A AC Current Probe, \$100.00; Model 1111A Amplifier, \$160.00.
		Prices f.o.b. factory
		Data subject to change without notice

NBS INAUGURATES HIGHER POWER VLF STANDARD FREQUENCY BROADCASTS

MANY readers will be interested in a recent announcement from the National Bureau of Standards that the NBS low-frequency standard broadcasts are now operating with greatly increased power.

Two new installations near Fort Collins, Colorado, have begun broadcasting the 20 kc VLF and 60 kc LF standard frequencies. These broadcasts, which were previously on an experimental basis from temporary transmitter sites, are received with greater accuracy than HF broadcasts (WWV, WWVH), according to NBS.

Transmissions from the 60 kc standard (WWVB) have a radiated power of 5 kw while the 20 kc standard (WWVL) has a radiated power of 1 kw. According to NBS, the 60 kc signal provides the more stable received frequency within a 2000-mile range, whereas the 20 kc signal is intended for global coverage. The stability of all Bureau stations is stated to be 2 parts in 10^{11} at the transmitters.

The improved receiving accuracy of low-frequency signals occurs because low frequencies rely on direct ground-wave propagation rather than on reflections from a shifting ionosphere as with high-frequency broadcasts. The frequency of VLF broadcasts, as received at a distant station, has about the same precision (1 part in 10^{10}), when averaged for a period of only 24 hours, as high frequency broadcasts that have been averaged for 30 days.

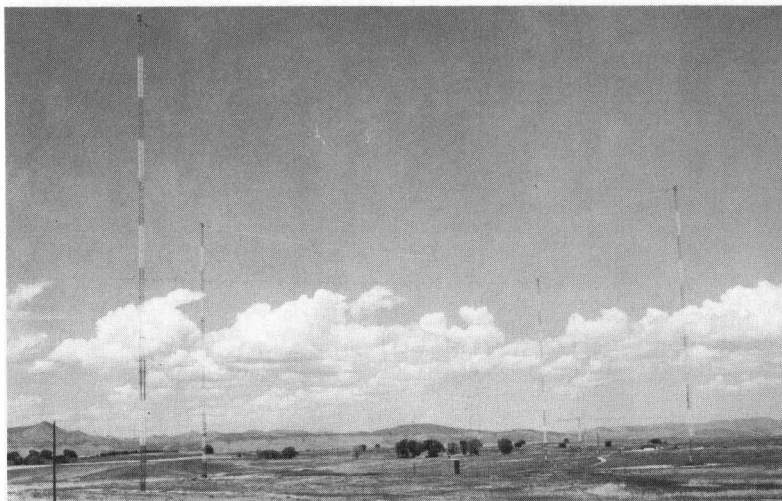

NBS low-frequency antenna installation at Fort Collins, Colorado.

The new stations do not replace WWV and WWVH, however, since these transmissions are sufficiently accurate for many important applications.

The experience of many users with the experimental VLF broadcasts has shown that it is possible to maintain a local frequency standard, using a high quality quartz oscillator, to an accuracy only about one order of magnitude less than an atomic frequency standard.

Some of the systems available for calibrating local frequency standards with reference to the national standards have been described previously in the *Hewlett-Packard Journal*.^{*} A complete discussion also is contained in -hp- Application Note No. 28, "Frequency and Time Standards."

* References in -hp- Journal

"Utilizing VLF Standard Broadcasts with the -hp- Frequency Divider and Clock" Vol. 11, No. 8-10, Apr.-June, 1960.

"A New Frequency/Time Standard with 5×10^{-10} /day Stability" L. S. Cutler, Vol. 12, No. 3, Oct., 1960.

"A New Clock for Improving the Accuracy of Local Frequency and Time Standards" D. Hartke, Vol. 11, No. 3-4, Nov.-Dec., 1959.

TIME SIGNAL PHASE ADJUSTMENT

The U. S. Naval Observatory and the National Bureau of Standards advise that standard broadcast time signals will be retarded 100 milliseconds on Nov. 1, 1963, at zero hours UT (7 pm EST of 31 Oct.). This adjustment is necessary because of speed changes in earth rotation. The last such adjustment was made Aug. 1, 1961. U. S. broadcasts affected include NBS stations WWV, WWVH, and WWVB and Navy stations NBA, NPG, NPM, NPN, and NSS.

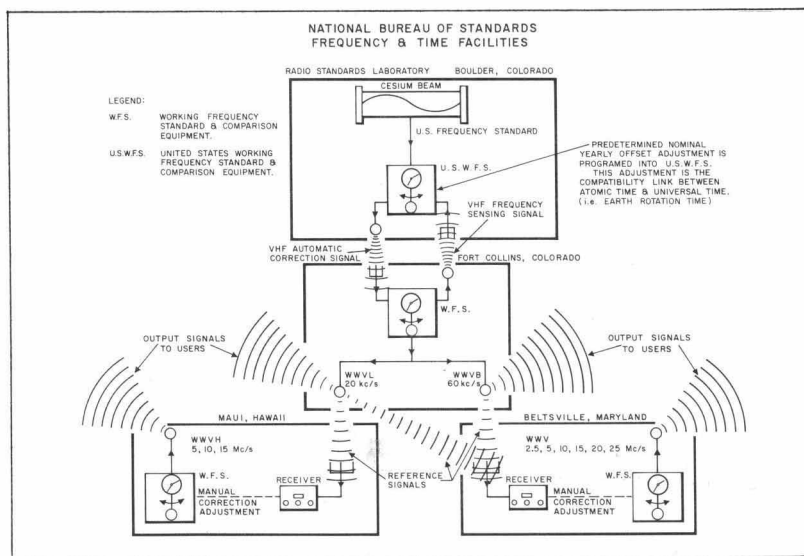

Source: NBS

Diagram shows relation between U. S. cesium beam frequency standard and standard frequency broadcast services provided by NBS.

NBS STANDARD FREQUENCY BROADCASTS

LOCATION	WWV ¹	WWVH ¹	WWVB	WWVL
	Beltsville, Md.	Maui, Hawaii	Fort Collins, Colo.	Fort Collins, Colo.
FREQUENCIES	2.5, 5, 10, 15, 20, 25 Mc/s	5, 10, 15 Mc/s	60 kc/s	20 kc/s
STANDARD RADIO FREQUENCIES	YES	YES	YES	YES
TIME SIGNALS	YES	YES	NO ²	NO ²
STANDARD AUDIO FREQUENCIES	YES	YES	NO	NO
STANDARD MUSICAL PITCH	YES	YES	NO	NO
RADIO PROPAGATION FORECASTS	YES	YES	NO	NO
GEOPHYSICAL ALERTS	YES	YES	NO	NO

¹ See NBS Misc Pub 236 or June, 1963 ISA Journal for additional information.

² To be added soon.